

Assembly Instructions - Model Chu-ko-nu

Step 1: The Stock Base

- A) Sand a bevel into the stock top and stock bottom as shown. Both are similar.

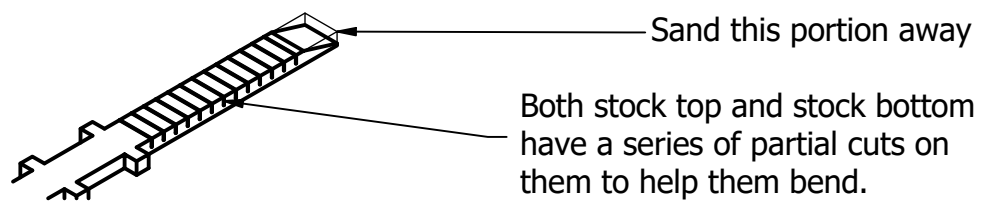

- B) Set both the stock sides out in mirror position as shown. Apply a light bead of glue as shown in green.

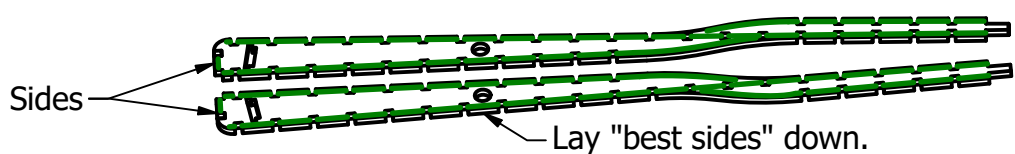

- C) Glue the strongback into the slots as shown, with the point forward. Add the top, bottom, and front. Add the remaining side.

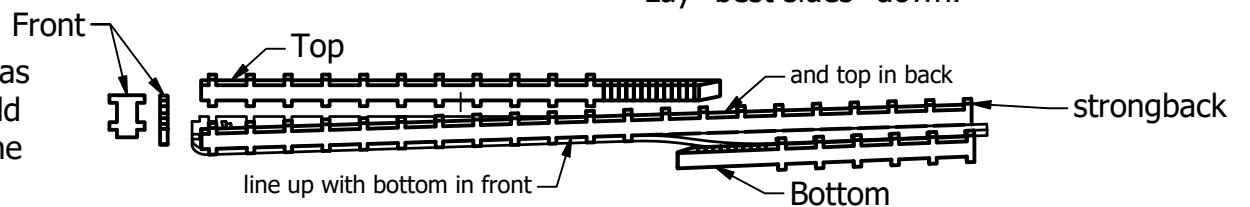

- D) Not shown. Wind rubber bands tightly around entire assembly to clamp while the glue dries. The rubber bands should force the top and bottom to bend to the same curvature as the stock.

Step 2: Handles and Cheeks

- A) Glue the toothpick into the two small holes on the stock cheeks. Just make the toothpick snug.

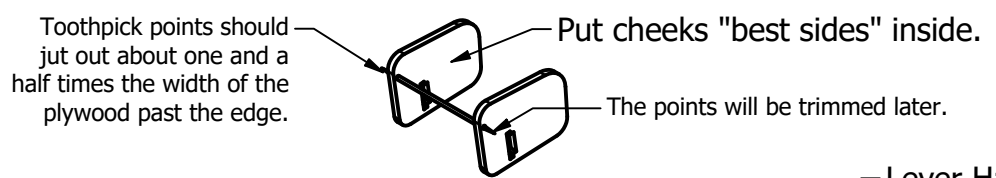

- B) Glue the three parts of the lever handle together, taking care to line them up.

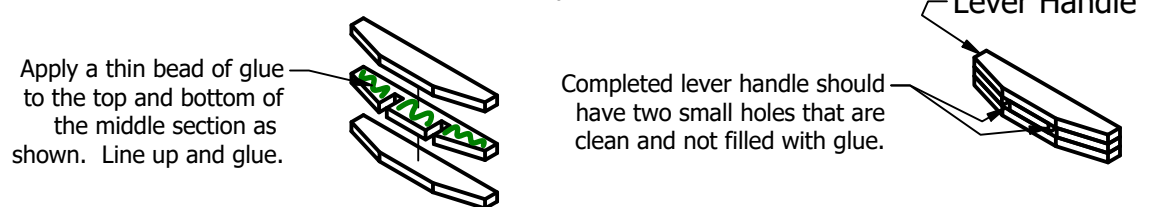

- C) Glue the four parts of the stock handle together as shown, taking care to line them up.

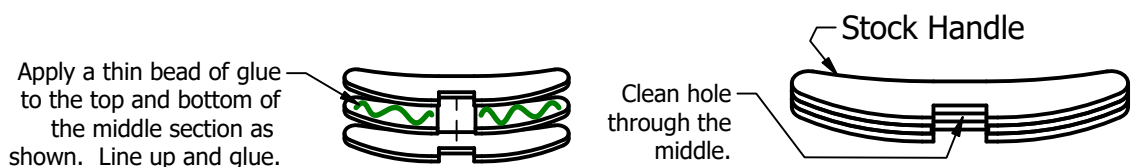

Secure the handles together with rubber bands if desired, and set aside to dry.

Step 3: The Bolt Box (or Magazine)

- A) Lay the two bolt box sides with their best sides downward in mirror position. Apply a thin bead of glue to the lines shown in green. Do not use too much glue.

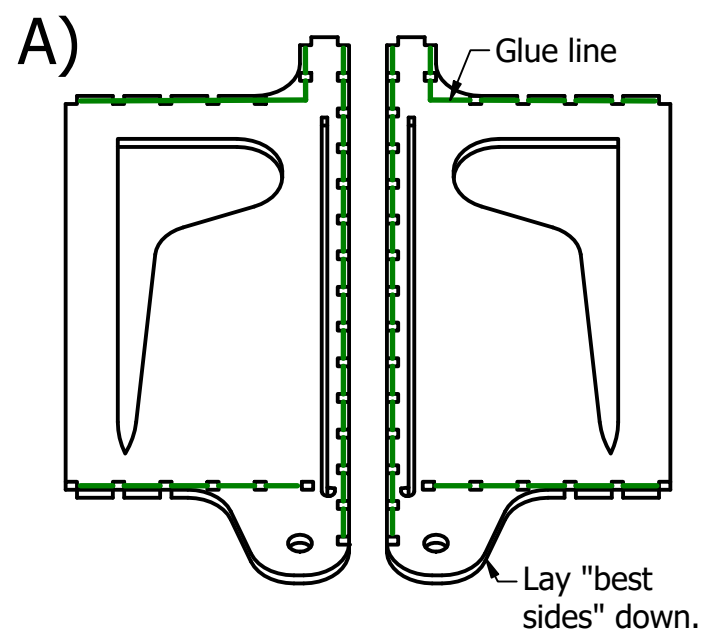

- B) Place the front, back, bottom, and top parts into their sockets, taking care to engage the tab on the front and top. Turn the other side over, and glue it down in place.

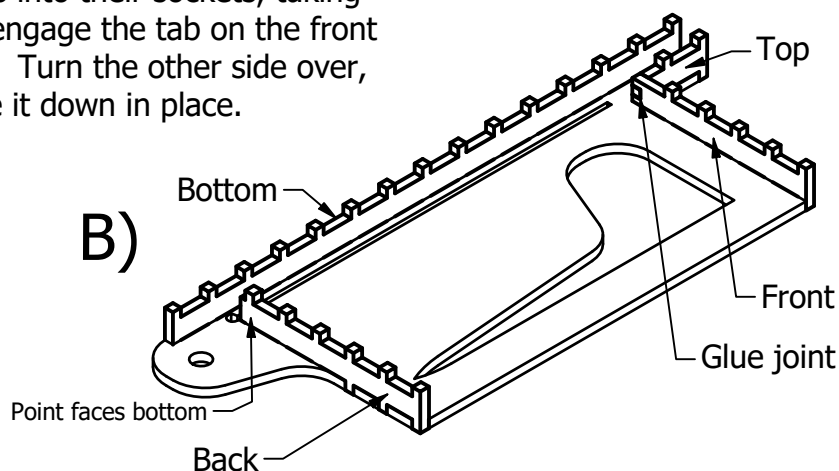

- C) Secure the two sides on the bolt box with rubber bands while the glue dries.

Step 4: Finish the Lever

Place a small dab of glue into each hole in the Lever Handle. Carefully insert the end of each lever side into the socket. Make sure both face the same direction and are even. Set aside to dry.

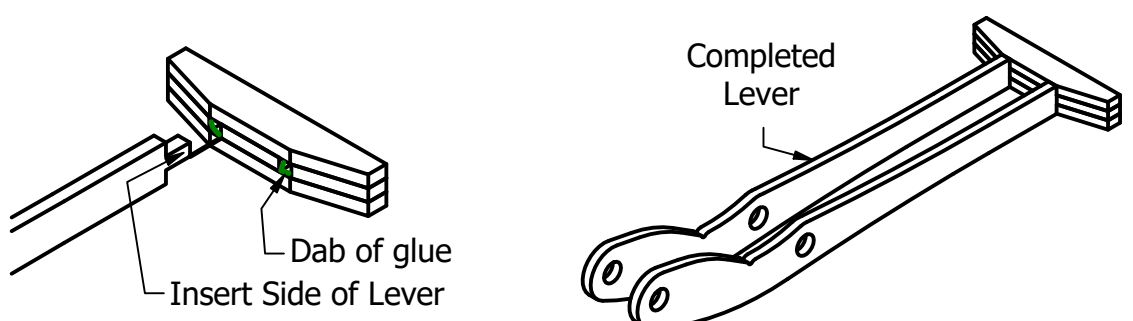

Step 5: The Stock Handle

Remove the rubber bands from the stock. Place dabs of glue as shown on the stock and the handle. Insert the stock into the handle. Use rubber bands to clamp while drying if desired.

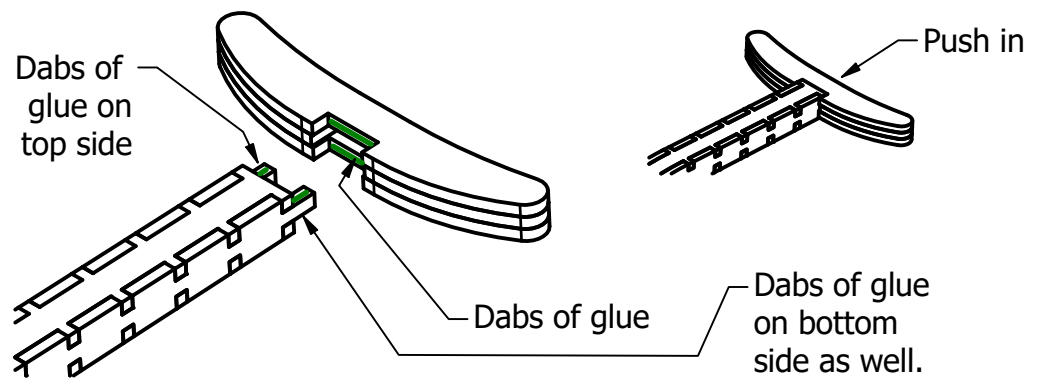

Step 6: Trim the Cheek Toothpick

Use a knife, scissors, or snips to trim the toothpick you already glued into the cheeks as shown, making two parts. Make sure you measure carefully. Too long, and the Chu-ko-nu won't fire. Too short, and it breaks.

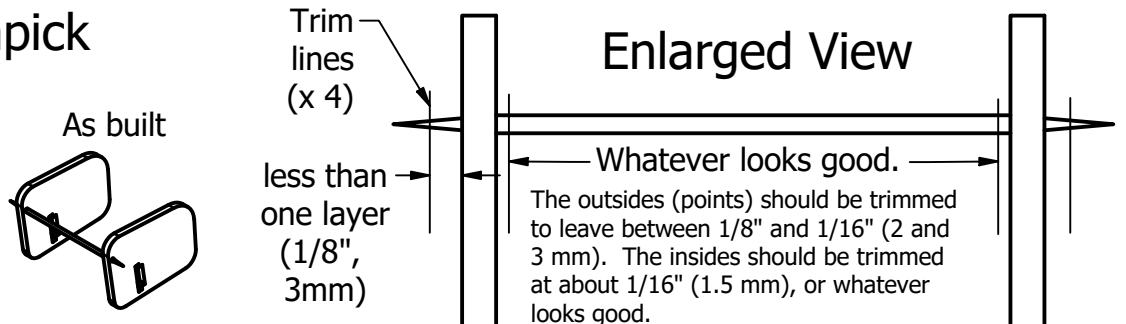

Step 7: Add the Bolt Box

A) Spread a light layer of glue where shown. Glue the stock cheek in position on the stock, being careful to keep it lined up.

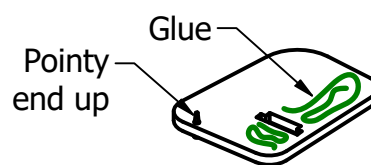

Use bow slot to help you line these up.

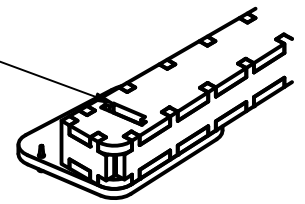

B) After glue dries, set the magazine in place over the cheek, with the pointed toothpick end in the slot as shown.

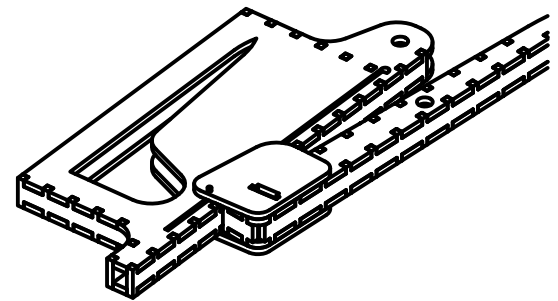
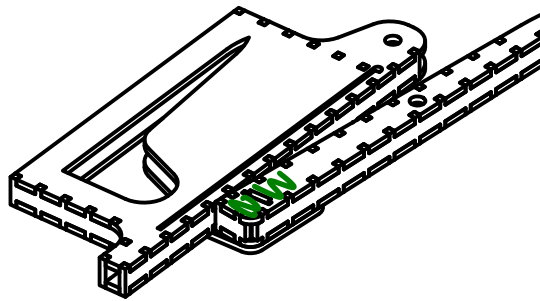
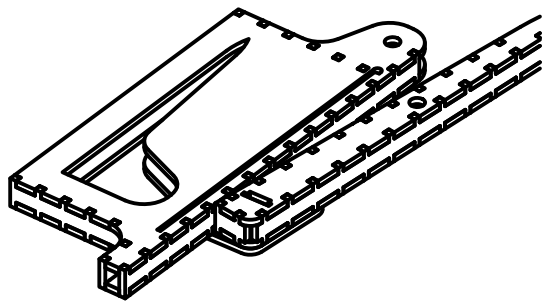

C) Add glue as shown in green, then glue down the other stock cheek, pointy end in the bolt box slot. Let dry.

Step 7 Alternative: Use the bow to help with alignment, and glue both cheeks onto assembly at the same time, over the bolt box. This is the method shown in the video. In any case, the box should now be attached, but moveable.

Step 8: The Lever

Ease the lever into the position shown, and pin the two holes with the 1/4" (6 mm) pins. Secure with dabs of glue on the outside layers only.

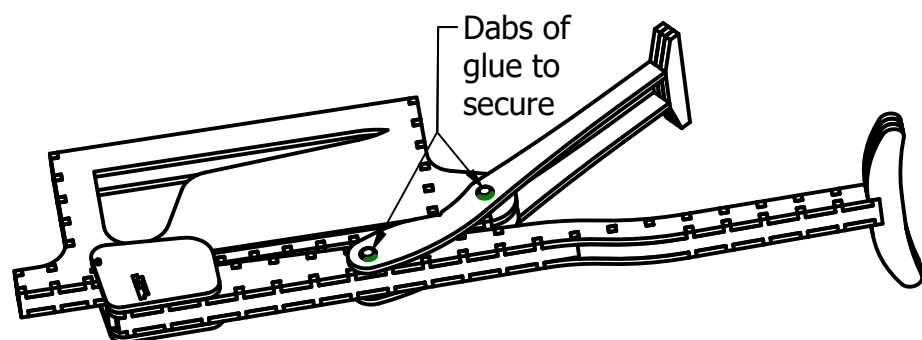

Step 9: The Bow

Hold the front and rear bows together, as shown. Gently slide them into the socket in the stock. Be careful, as they may fit quite tightly. Also note that they may have small splinters on them, so a light sanding before assembly is a good idea.

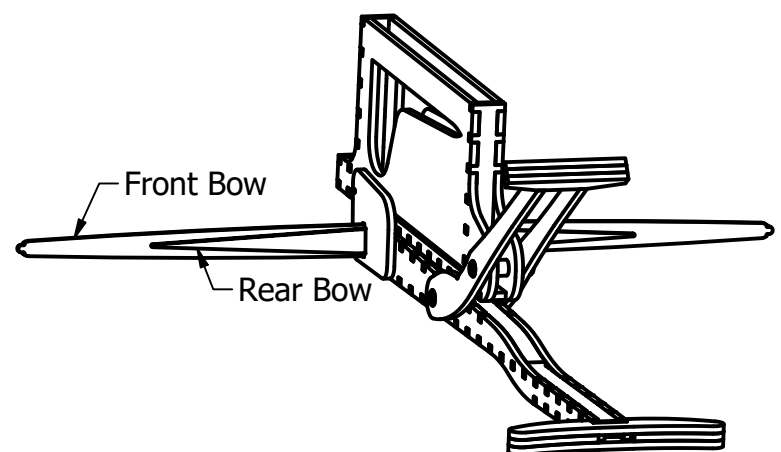

Step 10: The Bowstring

Tie small loops in the ends of the bowstrings. The bowstring should be 11" (28 cm) long end to long end. Insert the string through the large hole at the back of the slots. Carefully bend the bow, and slip the loops over the nubs at the ends of the bow. (Not Shown.)

Operating: Put pea-sized lumps of modelling clay in the ends of the coffee stirrers. Drop them into the bolt box, clay side forward. Pump the lever forward until the bowstring clicks into place. Pull backwards to fire.

Warning: As with any toy that fires, this toy presents an eye hazard. Wear eye protection while firing this model. Additionally, ensure that any other people in the area are also wearing eye protection. This model is intended for use only by or under the supervision of competent adults.